

* SU ECHIO TEST
 E REF TEST AGGIUSTARE
 VOLUMI PER ALMENO 10V_{PP}
 SE ALL'USCITA SI DESIDERA
 UNA TENSIONE ~ 10V_{PP}.

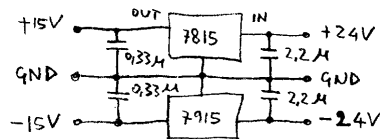

ETERODINA ECO

VERSIONE FINALE 5.3.80

Fig.2 The audio heterodyne shifted down the frequencies of the "echo in" band. In the configuration shown, the input band was 1550-2100 Hz and the output bands were two with center frequency respectively at 333 Hz and 667 Hz, depending on the frequency of the sinusoidal reference.

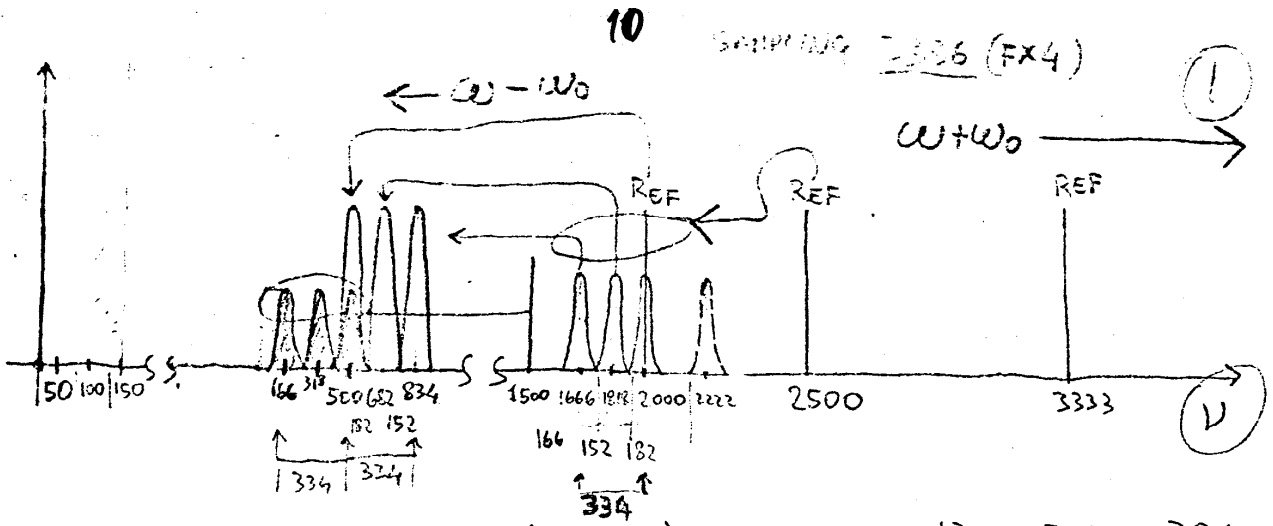

$$e(t) = E \sin(\omega t + \phi) \quad \alpha \quad 136 - 530 = 394$$

$$z(t) = R \sin(\omega_0 t + \phi_0) \quad \beta \quad 470 - 864 = 394$$

$e(t) \cdot z(t)$

$$\sin \alpha \sin \beta = \frac{1}{2} [\cos(\alpha - \beta) - \cos(\alpha + \beta)]$$

$$\alpha - \beta = \omega t + \phi - \omega_0 t - \phi_0 = (\omega - \omega_0)t + (\phi - \phi_0)$$

$$\alpha + \beta = \omega t + \phi + \omega_0 t + \phi_0 = (\omega + \omega_0)t + (\phi + \phi_0)$$

$$e(t) \cdot z(t) = \frac{1}{2} ER \left\{ \cos[(\omega - \omega_0)t + (\phi - \phi_0)] - \cos[(\omega + \omega_0)t + (\phi + \phi_0)] \right\}$$

Fig.3 The simple math behind the audio heterodyne. "Echo in" bands and reference signals.

RIF. 11

11

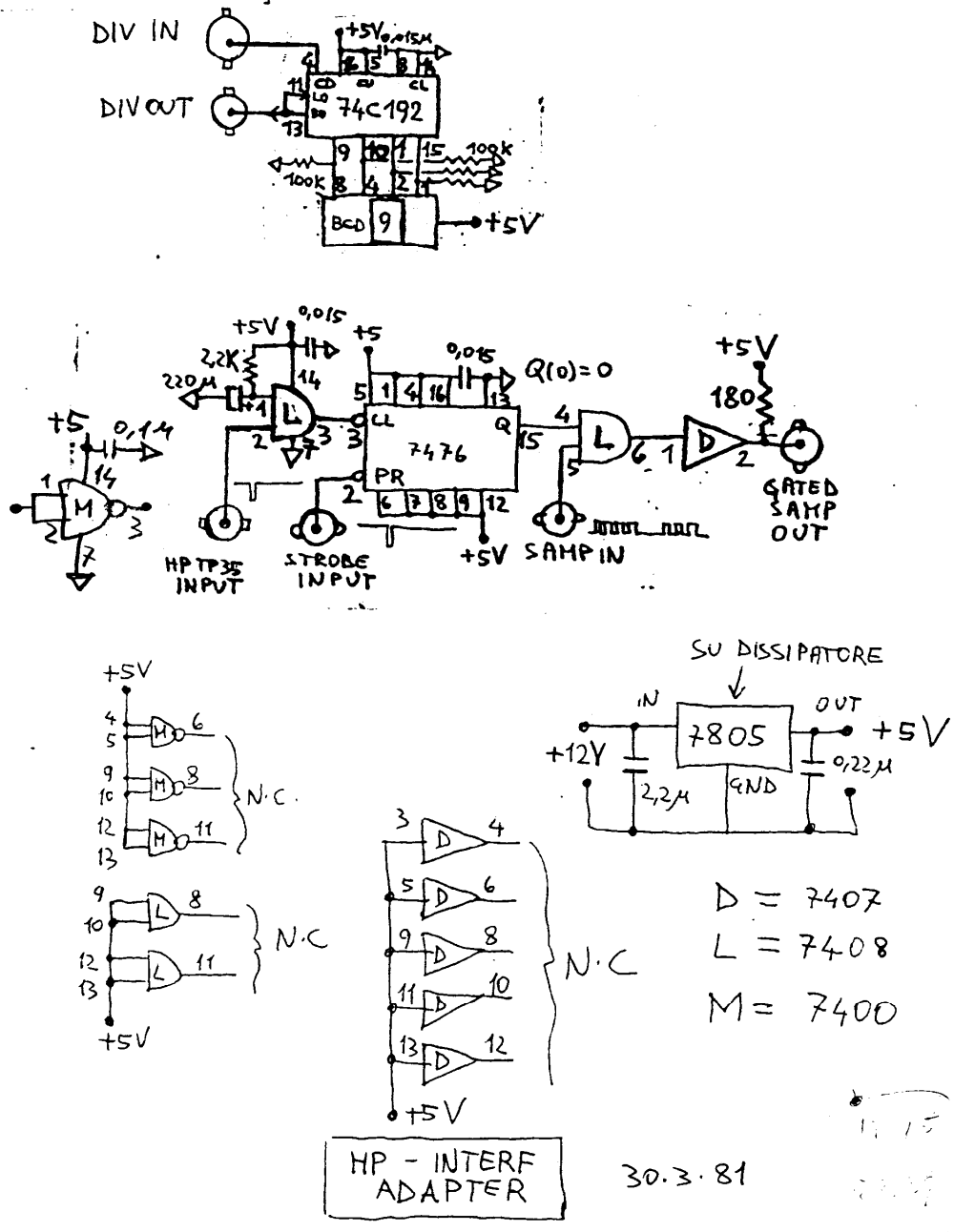

Fig.4 Sampling frequency divider and adapter. This circuit together with the circuit of Fig.1 allowed the production of synchronously generated gated sampling pulses with frequency $f_s = \frac{m}{n} f_R$, being f_R a sinusoidal reference and m, n integers, especially designed for use in undersampling.